

TH+ RANGE SLIDING

PRODUCT INFORMATION

Using 32- or 44-mm-thick double or triple glazing, the Vitrocsa TH+ range is for sliding window surfaces up to 18 m²+, depending on the glass supplier.

The excellent insulating properties of the profiles, in combination with the glass, enable current low energy consumption standards to be met.

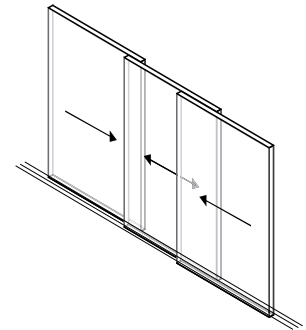

RAILS + FRAMES

- Embedded and concealed in the floor, wall and ceiling
- Frame just 140 mm wide for a birail (mono: 64 mm + 12 mm seal)
- Saline treatment specially adapted for coastal projects

CLOSURE MECHANISM

- 1-point closure button (029, 035, 055)
- Two-point closure button
- Cylinder
- Range of options for electric closure
- Alarms
- RC2 option

VERTICAL CONNECTION

- 22 mm
- Reinforced for very windy locations or installation at high altitudes

GLAZING

- 32 mm or 44 mm
- Panels up to 18 m² + (6 x 3.21 m), depending on the glass supplier, in vertical or horizontal position

MAIN CROSS SECTIONS

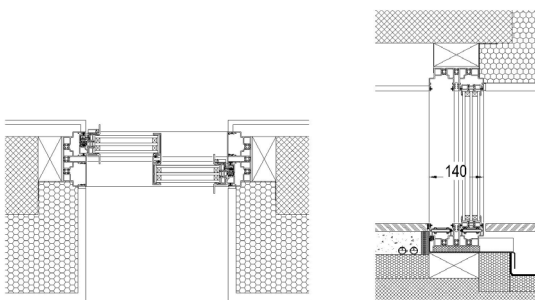

OPTIONS

- Standard sliding (up to 18 m²+)
- Sliding invisible frame with 2 grooves (up to 18 m²+)
- Curved (sliding: minimum radius 3 m/ fixed: minimum diameter 1.5 m)
- Fixed (up to 18 m²+)
- Open angle
- Pocket
- Motorisation
- Mosquito net built into the frame or panel
- Inner/outer incline

VITROCSA Headquarters
Orchidées Constructions SA
Rue de la Gare 8
2024 Saint-Aubin-Sauges
Switzerland

T +41 24 436 22 02
F +41 24 436 22 02
www.vitrocsa.com
info@vitrocsa.com

V I T R O C S A

THE MINIMALIST WINDOW

TH+ RANGE SLIDING

PERFORMANCE

To clearly demonstrate the properties of the VITROCSA 3001 SLIDING window, we have conducted standardised tests in an accredited laboratory (SWISS TESTING SERVICE NUMBER STS 317).

The results of these investigative tests are shown in the table below:

TH+ fixed-sliding	Standards (test and classification)	Classification
Air permeability	EN 1026 (test) EN 12207 (classification)	Class 3
Water permeability	EN 1027 (test) EN 12208 (classification)	Class 8A
Wind resistance	EN 12211 (test) EN 12210 (classification)	Class B5
Repeated opening/closing	EN 1191 (test) EN 12400 (classification)	Class 3 (20,000 cycles)
Resistance to a vertical load	EN 14608 (test) EN 13115 (classification)	Class 3 (600 N)
Resistance to break-ins	EN 1628 to 1630 (test) EN 1630 (classification)	WK2/RC2 (resistance class 2)

TH+ fixed-sliding MINERGIE frame	Standards (test and classification)	Classification
Air permeability	EN 1026 (test) EN 12207 (classification)	Class 4
Water permeability	EN 1027 (test) EN 12208 (classification)	Class 9A
Wind resistance	EN 12211 (test) EN 12210 (classification)	Class B3
Behaviour in different climates	EN 13420 (test)	There is no classification
Calculation of the Uw value and isotherm	EN ISO 10077-1, 2	Uw 0.97 W/(m ² K)

TH+ sliding-sliding	Standards (test and classification)	Classification
Air-borne noise insulation (measured in the laboratory) Glass: vPh 5/0.76/5 - 16 - vF5 total thickness: 31.8 mm	EN ISO 10140 (2010)	36 dB